

# Design of Inward-Turning External Compression Supersonic Inlet for Supersonic Transport Aircraft

Muhammad Adnan Utomo<sup>1,\*</sup>, Romie Oktavianus Bura<sup>2</sup>

**Abstract**—Inward-turning external compression intake is one of the hybrid intakes that employs both external and internal compression intakes principle. This intake is commonly developed for hypersonic flight due to its efficiency and utilizing fewer shockwaves that generate heat. Since this intake employ less shockwaves, this design can be applied for low supersonic (Mach 1.4 - 2.5) intakes to reduce noise generated from the shockwaves while maintaining the efficiency. Other than developing the design method, a tool is written in MATLAB language to generate the intake shape automatically based on the desired design requirement.

To investigate the intake design tool code and the performance of the generated intake shape, some CFD simulation were performed. The intake design tool code can be validated by comparing the shockwave location and the air properties in every intake's stations. The performance parameters that being observed are the intake efficiency, flow distortion level at the engine face, and the noise level generated by the shockwaves.

The design tool written in MATLAB is working as intended. Two dimensional axisymmetric CFD simulations validation has been done and the design meets the minimum requirement. As for the 3D inlet geometry, with a little modification on diffuser and equipping vent to release the buildup pressure, the inlet has been successfully met the military standard on inlet performance (MIL-E-5007D). This design method also has feature to fit every possible throat cross sectional shapes and has been proven to work as designed.

**Keywords**— Inward-turning, Supersonic, Engine Intakes, Low-noise, Design Method.

## I. INTRODUCTION

Supersonic intakes have a major role in supplying air to the engine exploiting shockwaves [1]. Air properties such as pressure, Mach number, and temperature must be met the engine needs by adjusting the shockwave position and strength. The efficiency of the intake must be maintained as high as possible and it is measured from the ratio of total pressure between at the engine face and at the undisturbed surrounding air. The most efficient intake configuration theoretically is the spike inlet which applies the conical supersonic flow. However, the spike intakes produce rather strong shockwave which directed to all direction. Thus, the spike intakes generate loud sonic boom and also higher drag in operation. Although the best efficiency spike intakes could offer, this intake configuration is not widely used. A better intake configuration has to be invented considering lower noise and higher efficiency for commercial supersonic aircraft.

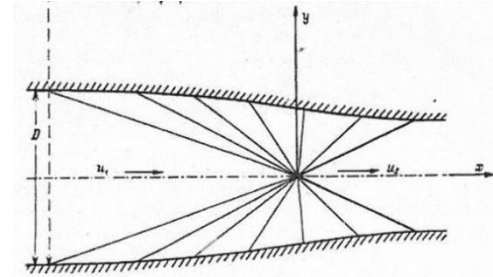

Fig. 1. Busemann Intake is the first Inward-turning principle ever proposed [2].

Inward-turning intake then is introduced to weaken the terminal shockwave. This design has several advantages including reducing shockwave drag, noise, and may also eliminate the complex support system for the intake such as adjustable spike position [3-7]. One of the well-known inward-turning intake is Busemann intake which theoretically the most efficient supersonic intake. Unlike spike intakes, the capture area of the inward-turning intake is not limited while able to maintain the spike intake's efficiency. However, the inward-turning intakes have limited spillage which can induce problems such as “unstart” [3]. This unstart condition must be avoided because this can cause engine burn out due to low air mass flow entering the inlet.

## II. THEORETICAL BASIS

In supersonic flows, the air properties changes are very extreme such as shockwaves. In the supersonic regime, the energy equation in Navier-Stokes equation cannot be neglected. The flow is no longer incompressible and the kinetic energy can be dissipated into heat. Thus, a sudden property changes can happen and it's called shockwave. The properties of shockwaves have been long known and their behavior when interacting with solid moving objects has been formulated. There are three main shockwaves, *Normal Shockwave*, *Oblique Shockwave*, and *Expansion Fan* [8].

### A. Normal Shockwave

When the shockwave appears perpendicular to the flow direction, it is called normal shock. This type of shockwave is irreversible process. Normal shockwave usually occurs when the flow is turned by large deflection in supersonic condition and the shock created cannot remain attached to the wall. The normal shockwave's behavior can be described as equations below.

$$M_2 = \sqrt{\frac{(\gamma-1)M_1^2+2}{2\gamma M_1^2-(\gamma-1)}} \quad (1)$$

<sup>1</sup>Aerospace Engineering, Faculty of Mechanical and Aerospace Engineering, Institut Teknologi Bandung Jl. Ganesha 10, Bandung 40132, Indonesia

**B. Expansion Fan**

Oblique shockwaves are similar to the normal shockwave unless they are not perpendicular to the flow direction. They work just like normal shockwaves but the flow is projected to direction that perpendicular to the oblique shockwave. Oblique shockwave occurs when the flow is compressed or contracted. The flow deflection angle can be determined with an equation called  $\theta - \beta - M$  relationship. Where  $\theta$  is the flow deflection angle and  $\beta$  corresponds the shock angle.

$$\tan\theta = 2\cot\left[\beta\left(\frac{M_1^2\sin^2(\beta)-1}{M^2(\gamma+\cos(2\beta))}\right)\right] \quad (2)$$

The property equation of oblique shockwave is similar, unless the flow direction must be projected to perpendicular to the shockwave first.

$$M_2 = \sqrt{\frac{(\gamma-1)(M_1\sin\beta)^2+2}{2\gamma(M_1\sin\beta)^2-(\gamma-1)}} \quad (3)$$

**C. Expansion Fan**

Expansion fan or widely known as Prandtl-Meyer Expansion fan is an expansion process when the supersonic flow turns around the sharp convex corner. This happens because expansion fans consist of infinite number of Mach waves [1]. The weakest point of an oblique shockwave or in other words that the flow speed is close to the speed of sound is called Mach wave. There are three main properties that characterize the expansion fan

- 1) The downstream Mach number is larger than the upstream or increasing the flow Mach number.
- 2) The Expansion Fan is actually the anti-thesis of oblique shockwave thus the density, pressure and temperature decrease through expansion fan.
- 3) Since it has infinitely number of Mach wave, the process is continuous inside the expansion fan between the forward and rearward Mach line. Angle of each mach line can be expressed where  $\mu_1 = \arcsin(1/M_1)$  and  $\mu_2 = \arcsin(1/M_2)$
- 4) The flow's streamlines through the expansion fan are smooth curved lines.
- 5) The expansion fan is an isentropic process because of continous process of Mach wave. Therefore, downstream properties can be calculated using isentropic relation.

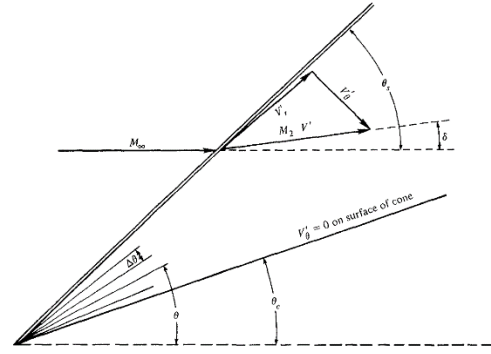

Fig. 2. Geometry for the numerical solution of Taylor-Maccoll equation

In practice, downstream Mach number is often needed to find the downstream properties. The Prandtl-Meyer function (often symbolized as  $v$ ) is a function to find the downstream Mach number in calorically perfect gas assumptions.

$$v(M) = \sqrt{\frac{\gamma+1}{\gamma-1}} \tan^{-1}\left(\sqrt{\frac{\gamma+1}{\gamma-1}(M^2-1)}\right) - \tan^{-1}\sqrt{M^2-1} \quad (4)$$

$$\theta_2 = v(M_2) - v(M_1) \quad (5)$$

In three-dimensional space, the supersonic flow is not as restricted as the two-dimensional space. Therefore, Conical supersonic flow has its own calculation which works in three-dimensional space. Since conical shape can be simplified into two dimensional axisymmetric, assumed the calculation is done in spherical coordinates, this calculation only needs to observe two directions namely radial and axial direction.

The supersonic flow over cone bodies or conical flow is expressed by Taylor-Maccoll equation respecting the conservation of momentum and based on Euler equation.

$$\frac{\gamma-1}{2} \left[ V_{max}^2 - V_r^2 - \left(\frac{dV_r}{d\theta}\right)^2 \right] \left[ 2V_r + \frac{dV_r}{d\theta} \cot\theta + \frac{d^2V_r}{d\theta^2} \right] - \frac{dV_r}{d\theta} \left[ V_r \frac{dV_r}{d\theta} + \frac{dV_r}{d\theta} \left(\frac{d^2V_r}{d\theta^2}\right) \right] = 0 \quad (6)$$

where

$$V_\theta = \frac{dV_r}{d\theta} \quad (7)$$

$$\frac{v}{V_{max}} \equiv V' = \left[ \frac{2}{(\gamma-1)M^2} + 1 \right]^{-0.5} \quad (8)$$

In designing the inward-turning Busemann intake, the supersonic flow streamline must be determined first. Later, this streamline can be replaced as intake wall. In order to find the

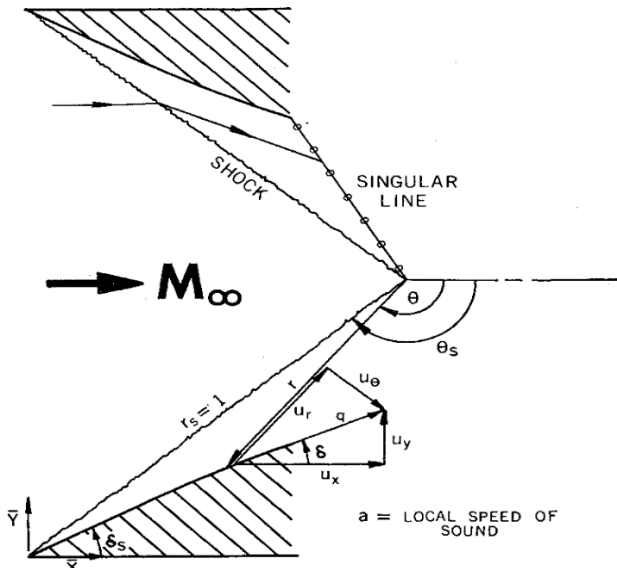

Fig. 3. Notation for Internal Conical Flow A (ICFA)[6].

streamline, Busemann parent flowfield equation, Taylor-Maccoll equation discussed in previous subsection, is used. As opposed to the conical flow, the flow inside Busemann intake is turned inward to the center line axis. The calculation process is also reversed where the calculation must be started at the downstream area of the intake [5]. Therefore, it needs boundary condition such as the exit Mach number, the freestream Mach number, and the terminal shockwave angle. Since the calculation process is done in non-dimensional, the design result is resizable and can be fit to the engine specification.

Even though it has the best efficiency compared to other intake design, disadvantages using this kind of intake has been discovered and has been the main problem to solve in the last decade. Busemann intake needs very long structure to achieve its highest efficiency through isentropic compression. Long intakes can also cause friction loss from the wall and increase structural weight. Busemann intake is also sensitive to the angle of attack which may now work for a slight angle of attack. Moreover, due to very precise geometry, it is not "self-starting" as opposed to the conventional ramp intake that can be easily started. Some modification for Busemann intakes have been discovered recently to reduce these disadvantages.

One of many solutions to solve the truncated area problem, at the leading edge, an Internal Conical Flow A (ICFA) principle can be applied. It was first discovered by Sannu Molder as one of four solutions to the Taylor-Maccoll equation. The ICFA principle is similar to the flow over cone body but reversed. The flow is inward turned, satisfying for the Busemann intake needs.

Unlike the Busemann intake, which the flow inside follows the wall, ICFA flow is not directly follow the wall rather slowly turned the direction after oblique shockwave until parallel to the wall and the singularity point is reached which pretty similar to the flow behaviour over cone body [6]. ICFA can be the solution for truncation of Busemann intake. Rather than using truncation angle as the design parameter, first

deflection angle (denoted by  $\delta_s$ ) is better. The ICFA then is merged to the truncated Busemann intake at the singularity line.

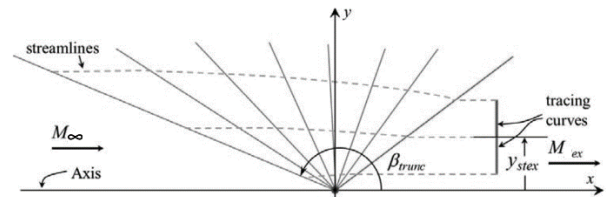

Fig. 4. Integration of streamline from the tracing curve.

At the merging point, the flow properties such as Mach number and flow direction must be fit to each other. Expansion fan would appear since the flow direction between ICFA and truncated Busemann intake is different. Thus, this merging point must be calculated in iterative process and can be useful to determine the suitable terminal shock angle.

Calculation until merging procedure is still in quasi one-dimensional view or simply a two-dimensional design.

However, this calculation can be converted into three dimensional by replacing the streamline with intake's wall. The three-dimensional streamline can be generated from the axisymmetric parent flowfield calculated before. Thus, a tracing shape is needed to shape the overall intake [3],[4],[16].

By placing the tracing curve inside the parent flowfield, its role is to be the initial seed for generating streamline. By definition, no flow crosses streamline. Therefore, the network streamlines can be replaced by a solid surface defining the intake's wall [9]. The axial projection of the leading edge onto a plane perpendicular to the axis-of-symmetry defines the shape of the capture cross-section of the intake. The area of the capture cross-section is the theoretical capture area of the inlet.

## II. NUMERICAL IMPLEMENTATION AND TOOL DEVELOPMENT

In general, this inlet is divided into two main parts; ICFA section and Inward Turning Busemann section. These two sections are calculated separately while the design iteration process is in sync with each other following the merging procedure. Flowchart shown is the main calculation process on how this tool designs and generate the supersonic inlet in both 2D and 3D.

### A. ICFA Design Calculation

Internal Conical Flow A (ICFA) is a type of supersonic inlet which derived from the Taylor-Maccoll equation with constant deflection angle along the wall. Therefore, based on these condition, a singularity could be found in Taylor-Maccoll equation which become the end of ICFA section. Beyond this singularity point, either separation would occur or a shockwave might appear.

The deflection angle or the lip angle is determined first. As the lip angle increase, the oblique shockwave it produces will get stronger and vice versa. Stronger oblique shockwave creates lower Mach number at the downstream side, therefore the required inlet length is decreased. Even though the length is shorter, the total pressure recovery is also decreased. It needs a certain balance of lip deflection angle because it

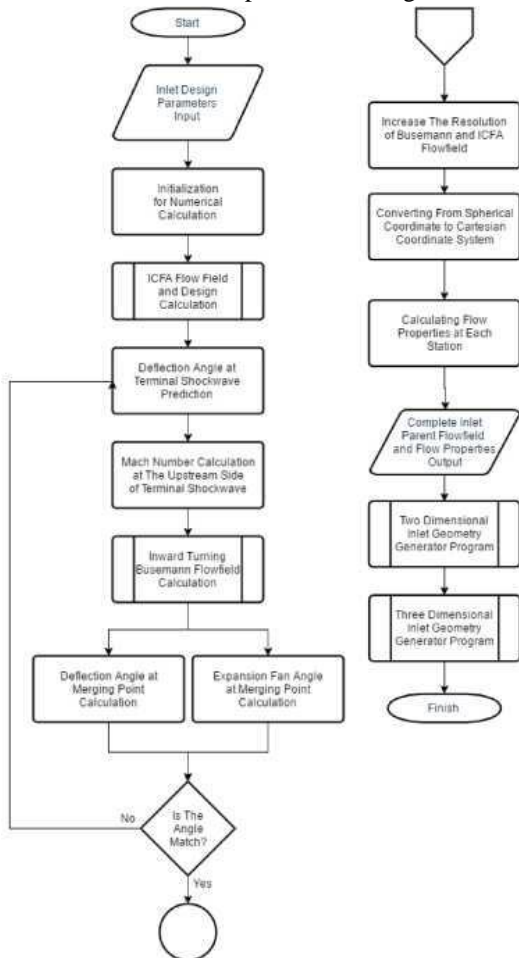

determines the rest of the inlet design.

Fig. 5. Work flow diagram showing the calculation process in designing the Inward Turning Busemann Supersonic Inlet

### B. Busemann Inlet Design Calculation

In this inlet section, an isentropic compression process occurs. The flow in this section is turned inward respecting the Taylor-Maccoll equation and at the same time decreasing flow's Mach number [5]. In contrast to ICFA section where the wall is constant at certain angle, the Inward Turning section (or Busemann Inlet section) wall is generated from flow's streamline that respects the Busemann Parent Flowfield

generated from the Taylor-Maccoll equation. This flowfield is the important key in producing the Inward Turning Busemann Inlet.

The BusemannFlowfield is calculated from downstream to the upstream the opposite of the ICFA. Therefore, the downstream air properties is needed for the boundary condition for solving the flowfield equation. In Taylor-Maccoll equation, the angle ( $\delta$ ) that represents location in polar coordinates is the driving variable or the flowfield scope. In ICFA flow calculation, singularity is present at certain angle and it becomes the end of ICFA section. This angle then is used as the upper limit of the BusemannFlowfield. While the terminal shock angle, which is predicted first, is used as the lower limit.

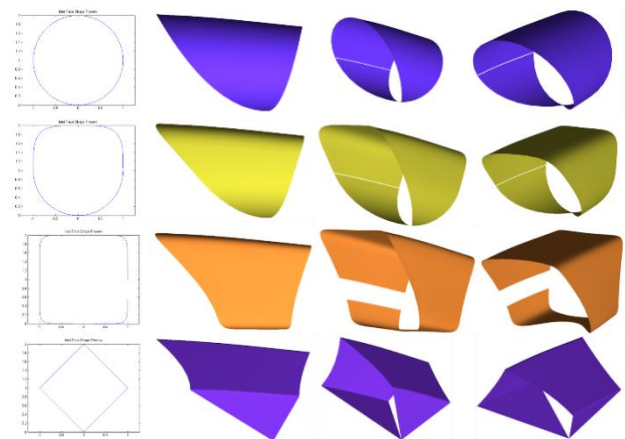

Fig. 6. The 3D geometry output from the MATLAB codes. The 0.9 exit Mach number design is used as example. Throat cross-sectional shape from the top: circle, flat-top, square, diamond

### C. Merging Procedure

The merging procedure follows after the Busemann section calculation. This procedure ensures the flow is matched between the end of ICFA section and at the beginning of the Busemann section thus it flows continuously without interruption. Since the flow angle between these section is different, a turning point between these sections must be placed by either generate oblique shockwave or expansion fan. However, in this case, the lip deflection angle is steeper than the flow direction at the leading part of Busemann section thus an expansion fan is expected to occur at the merging point.

Up to this point, two flow angle difference between these two sections can be calculated which the angle difference produced from ICFA and Busemannflowfield calculations and from the expansion fan equation. The flow angle difference from the expansion fan can be acquired from known Mach number at both ICFA section exit and Busemann section entrance. These flow angle difference must be match to satisfy the flowfield criteria and expansion fan phenomena. If they don't match, the calculation must be repeated again with different guessed terminal shock angle knowing that the ICFA section exit condition always constant

until both flow direction difference match. Thus, the Busemann section design must be refitted until correct terminal shock angle is found.

### III. DESIGN TOOLS OUTPUT

This design tool produces the 3D geometry which the method is already discussed. The 3D inlet is defined by streamline tracing that follows the Busemann Parent Flowfield and pre-defined tracing curve. Different tracing curves will produce a completely different inlet shape. For demonstration, four different tracing curve such as circle, circle with flat side at the top, diamond shape, and square with rounded corner. Each 3D inlet geometry from those tracing curves will be represented. However, only two tracing curves that will be used for 3D CFD simulation which are the circle shape and the circle with flat side at the top. This demonstration shows how flexible the design tool can be which can be used for better integration with the fuselage or aircraft's wings.

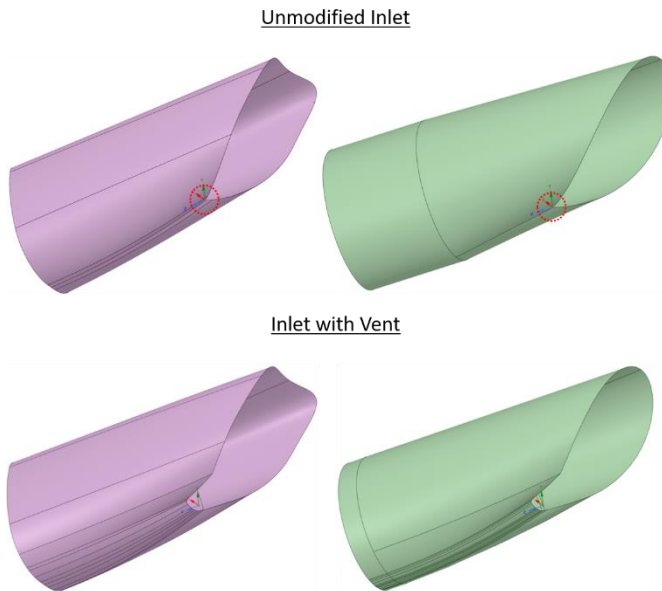

Fig. 7. The comparison between the unmodified inlets and inlets after vent is added. Red circles shows where the inlet's focal point is.

Table 1. Atmosphere condition at 14000 m from sea level with 15° C temperature offset

Air Properties	Value
Temperature	231.65 K
Pressure	14100 Pa
Density	0.2121 kg/m <sup>3</sup>
Speed of Sound	305.113 m/s
Dynamic Viscosity	0.0000151601 Pa.s

Since this inlet is designed without using any bleed system thus making it difficult to start, thus a vent is needed. The purpose of this vent was to allow increased flow spillage during starting and sub-critical operation of the inlet. The

main cause this inlet is hard to start is because the flow is focused in a single point which is at the focal point that blocks the flow and therefore spillage is needed to get back to critical operation where the inlet can work at the upmost efficiency. The vent region is modified by specifying a new downstream cowl lip location along with azimuthal angles to define the extent of the modification. The cowl was translated aft by an axial distance equal to 55 mm to the downstream. The upstream half angle was set to 21° and was used to specify the circumferential extent of the modification on the original cowl lip.

### IV. 3D SIMULATION VALIDATION

The validation of this design is done using Computational Fluid Dynamic (CFD) approach. Some simulation is done to represent the inlet design performance at different working condition. The inlet simulation is done with free stream velocity at Mach 1.7 and at altitude of 14 km. The air properties in this condition are specified in Table 1. In this research, the mass flow is the variable for the simulation as it represents the inlet working condition. These simulations also ensure that the inlet will fit the minimum requirement of the engine. In this case, the GE F414 turbofan engine is used as reference. The main reason is this engine is going to be used by the future supersonic aircrafts.

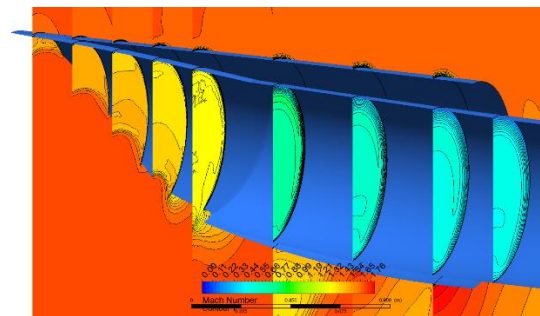

Fig. 8. Mach contour in every section inside the modified circle throat inlet case showing the conical shockwave from the leading edge.

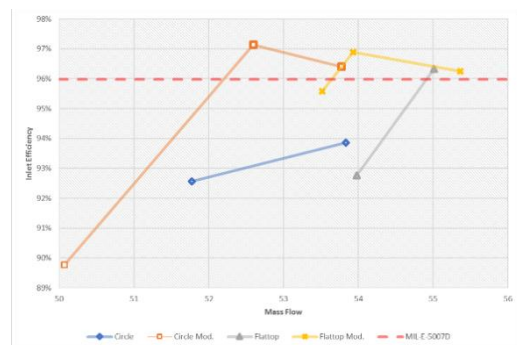

Fig. 9. Each inlet performance compared to MIL-E-5007D inlet efficiency standard. The minimum uncorrected mass flow required is 48 kg/s.

By design, there would be two shockwaves in the shape of cone generated by the inlet. The first conical shockwave appears at the inlet's lip or inlet's leading edge that spans up to

the inlet's focal point or the venting area. The conical shockwave formed from the leading edge to the focal point. This proves that the 3D inlet design is working as designed and the design methodology is proven and can be applied in 3D inlet. The terminal shockwave in the other hand, it is difficult to see whether it is a conical or planar shockwave since by design, the cone angle is so large and it almost resemble normal shockwave. This would affect the inlet performance, since the isentropic compression is disturbed by the terminal shockwave, stronger terminal shock would appear which reduce the total pressure recovery.

In comparison with the circle shaped throat design, the inlet performance of the flattop design is slightly worse. The only problem arise here is the distortion shape imprints the throat shape. A separation is found in supercritical condition but it is still small compared to the whole engine face area. This also affect inlet's total pressure recovery which at critical condition. The maximum total pressure can be achieved by the inlet is only 96.9% compared to 97.1% for circular design. But these number still meet the MIL-E-5007D standard. Overall, these flattop design work as intended can be used for real world application.

The minimum mass flow required that needs to be supplied to the engine while the engine working at full thrust is 77.1 kg/s. This mass flow is measured at sea level condition. This is the reference of the mass flow required. However, this requirement changes that depend on the atmospheric condition due to the conservation of mass. Therefore, the corrected mass flow is needed. Usually, at higher altitude, engine needs less mass flow to work [14]. Here the minimum mass flow required at the altitude of 14,000 m is 48 kg/s which if mass flow correction formula is added, the corrected mass flow is exactly 77.1 kg/s. All inlet designs are able to supply enough airflow to F414 engine.

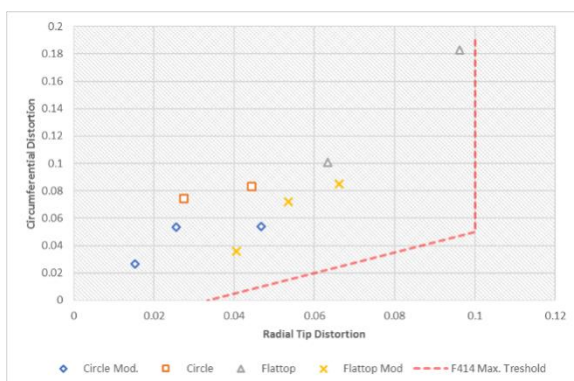

Fig. 10. Distortion of each inlet design compared to F414 maximum distortion threshold.

The radial and circumferential distortion intensity are represented as a scatter graph to illustrate the inlet's distortion level compared to maximum distortion level allowable by the F414 engine. All inlets are met the distortion level criteria. The circle throat design has lower distortion level compared to the flattop design. This is due to the absence of shape transition in circular throat design. The unmodified inlets have higher distortion level than the modified one. Then it

can be concluded that the vent has a role to reduce the distortion level in inward-turning inlet design.

## V. CONCLUSION

The inlet design methodology for supersonic inward-turning inlet has successfully been developed. The design method has been written into a code to automatically generate the inlet geometry and its theoretical performance. Then, the inlet generated from this code is simulated to validate the design method and the tools written in MATLAB. Overall, the design tools and the design method are validated and proven that this design tool can produce an inlet geometry that works as intended.

The ICFA flowfield was used to incorporate the inward-turning cowl leading edge for low drag and sonic boom. This was merged with a Busemann conical compression, terminating in a strong oblique wave. This design methodology allows inlet designer to freely shape the inlet since one of this inlet's design parameter is throat shape. Therefore, this design methodology is perfect for inlets which blends with diffuser although this claim might need to be proven. But, theoretically this design method could produce every possible inlet's shape. From the code validation, we also know that the design parameter of Mach 0.9 exit Mach number is consistent with MATLAB code calculation. Thus, Mach 0.9 exit Mach number design is chosen for 3D inlet's reference design.

The inward turning design performs as expected. All inlet design with venting modification can perform better than MIL-E-5007D standards at critical condition which can achieve efficiency as high as 97.2%. This efficiency can be cranked up even further if active boundary layer control system is equipped. However, the unmodified inlets do not perform any better and failed to satisfy the standards. Overall, the inlet with circle throat is better by a small margin than the flat top throat design. Inlet distortion level of all inlet designs are still acceptable for F414 engine use. The circle throat design has lower distortion level than the flattop throat design. It is recommended to use the circle throat design if possible.

## REFERENCES

- [8] Anderson, John D. *Modern Compressible Flow: With Historical Perspective*. Boston: McGraw-Hill, 2003.
- [1] Ascher, Uri M., and Linda R. Petzold. *Computer Methods for Ordinary Differential Equations and Differential-Algebraic Equations*. Philadelphia: SIAM, 1998.
- [2] Otto, Samuel E., Charles J. Trefny, and John W. Slater. *Inward-Turning Streamline-Traced Inlet Design Method for Low-Boom, Low-Drag Applications*. Cleveland: NASA Glenn Research Center, 2015.
- [3] Slater, John W. *Methodology for the Design of Streamline-Traced External-Compression Supersonic Inlets*. American Institute of Aeronautics and Astronautics, 2014.
- [2] Milder, S. and Szpiro, E.J. Busemann Inlet for Hypersonic Speeds. *AIAA Journal of Spacecraft and Rockets*, Vol. 3, No.8, pp. 1303-1304, 1966.
- [4] Milder, S. *Internal, Axisymmetric, Conical Flow*. *AIAA Journal*, Vol. 5, No. 7, Jul. 1967, pp. 1252-1255.

- [5] Zhao, Zhi, Wenyang Song. *Effect of Truncation on the Performance of Busemann Inlet*. Canada: CCSE Modern Applied Science Journal, 2009.
- [6] O'Brien, Timothy F. and Jesse R. Colville. *Analytical Computation of Leading Edge Truncation Effects on Inviscid Busemann Inlet Performance*. Reno: AIAA Aerospace Sciences Meeting and Exhibit, 2007.
- [7] Xiao, Yabin, Lianjie Yue, Peng Gong, and Xinyu Chang. *Investigation on a Truncated Streamline-Traced Hypersonic Busemann Inlet*. Dayton: AIAA International Space Planes and Hypersonic Systems and Technologies Conference, 2008.
- [8] Ramasubramanian, Vijay, and Mark Lewis. *Performance of Various Truncation Strategies Employed on Hypersonic Busemann Inlets*. AIAA/DLR/DGLR International Space Planes and Hypersonic Systems and Technologies Conference, 2009.
- [9] You, Yancheng, Chengxiang Zhu, Junliang Guo. *Dual Waverider Concept for the Integration of Hypersonic Inward-Turning Inlet and Airframe Forebody*. AIAA/DLR/DGLR International Space Planes and Hypersonic Systems and Technologies Conference, 2009.
- [7] Courant, Richard, Friedrichs, K.O. *Supersonic Flow and Shock Waves*. New York: Springer-Verlag, 1976.
- [10] Hutomo, Muhammad Adnan. *Desain Konseptual Mixed-Compression Intake pada Kecepatan High Supersonic*. Institut Teknologi Bandung, 2015.
- [1] Mattingly, Jack D. *Aircraft Engine Design*. Virginia: American Institute of Aeronautics and Astronautics, 2002.
- [11] *Guide for the Verification and Validation of Computational Fluid Dynamics Simulations*. Renton: American Institute of Aeronautics and Astronautics, 1998.
- [12] Slater, John W. *Design and Analysis Tool for External-Compression Supersonic Inlets*. Cleveland: American Institute of Aeronautics and Astronautics, 2012.
- [13] Bloch, Gregory S. *An Assessment of Inlet Total-Pressure Distortion Requirements for the Compressor Research Facility*. Ohio: Aero Propulsion and Power Directorate, 1992.
- [14] Farmer, Clinton J. *Inlet Distortion, Vorticity, and Stall in an Axial-flow Compressor*. Springfield: Naval Postgraduate School Thesis, 1972.